

# User Instructions

Suitable for dimmable LED lamp, dimmable CFL lamp, incandescent & halogen lamp.

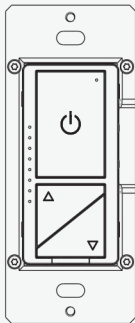

## 2. Functional Specifications

### Dimmer

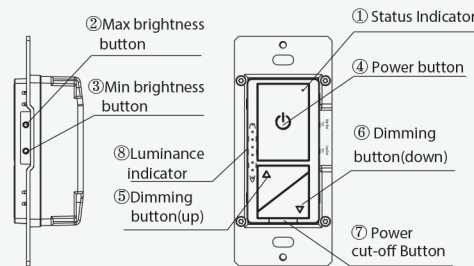

#### ① Status Indicator

- 2.1.1 Indicator lights red: OFF status
- 2.1.2 Indicator lights white: ON status

Short press: Within 0.5s
Long press: Over 0.5s
Continuous short press: Each interval of short press should within 0.3s

#### ② Max. Brightness Button

2.2.1 Setting the max. brightness: There are 6 max. brightness levels, short press the button of max. brightness once can change a max. brightness level.

#### ③ Min. Brightness Button

2.3.1 Setting the min. brightness: There are 6 min. brightness levels, short press the button of min. brightness once can change a min. brightness level.

#### ④ Power Button

- 2.4.1 Turn on: Short press once when in OFF.
- 2.4.2 Turn off: Short press once when in ON.

2.4.3 Min. brightness setting: Turn the light to ideal brightness and short press the power button for 6 times when in ON.

2.4.4 Max. brightness setting: Turn the light to ideal brightness and short press the power button for 8 times when in ON.

2.4.5 Clear Brightness Setting: Continuous short press the power button 9 times when in ON.

2.4.6 Restore factory setting: Short press the power button for 10 times, the status indicator blinks 3 times to restore factory setting. (1. Turn on the bulb to be in the brightest state. 2. Clear all remote pairing)

#### ⑤ Dimming Button (UP)

2.5.1 Short press the dimming button once can increase a level of brightness when in ON status.

2.5.2 Long press the dimming button can continuous to increase the brightness until release or reach the maximum brightness.

2.5.3 Continuous short press 2 times when in ON/OFF status to turn quickly to the full brightness.

#### ⑥ Dimming Button (Down)

2.6.1 Short press the dimming button once can decrease a level of brightness when in ON status.

2.6.2 Long press the dimming button can continuous to decrease the brightness until release or reach the minimum brightness.

2.6.3 Continuous short press 2 times when in ON/OFF status to turn quickly to the min. brightness.

#### ⑦ Power Cut-off Button

2.7.1 Put in the power cut-off button to connect the power.

2.7.2 Put out the power cut-off button to cut off the power.

#### ⑧ Luminance Indicator

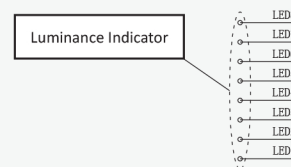

Item	Luminance Level	Luminance Indicator
1	Luminance 1~2	LED 1 normally on
2	Luminance 3~4	LED 1~LED 2 normally on
3	Luminance 5~6	LED 1~LED 3 normally on
4	Luminance 7~8	LED 1~LED 4 normally on
5	Luminance 9~10	LED 1~LED 5 normally on
6	Luminance 11~12	LED 1~LED 6 normally on
7	Luminance 13~14	LED 1~LED 7 normally on
8	Luminance 15~16	LED 1~LED 8 normally on

## Switch Operation

Turn on: Switch on when the light is off.

Turn off: Switch on when the light is on.

## Accessory Information

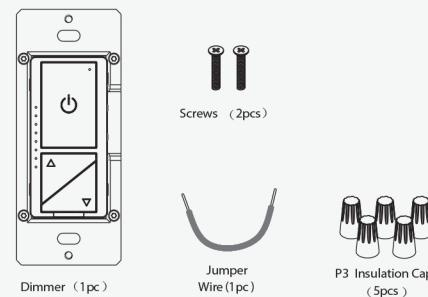

## 3. Tools Needed To Install

5mm Philips Screwdriver	Test Pencil
Electrical Tape	Plier
Cutter	Ruler

## 4. Installation

4.1 **WARNING:** To avoid fire and electrical shock, TURN OFF POWER at circuit breaker or fuse and test that power is off before wiring.

4.2 Remove the screws installed on the existing panel and switch, carefully pull out the switch from the wall box, identify and remove the power cord attached to the switch, and the switch, do not remove the power cord detached from the switch. (This step is not required for new configuration installation.)

#### 4.3 Identify Location 1 cord type

Note: If the power cord in the wall box is different from the following layouts, please consult an electrician.

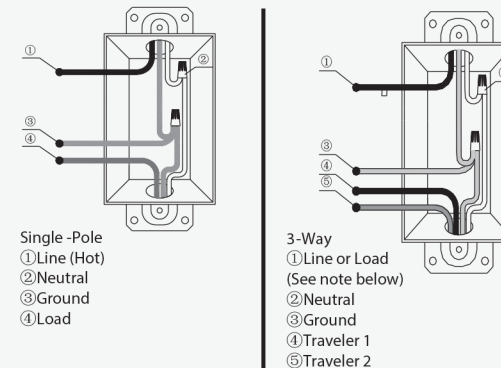

**IMPORTANT** Please note that for 3-way application, there have a power cord from the original switch be a different color (Black) or marked Common. Finding this power cord from both the dimmer's junction box and 3-way junction box and marking as common (live or load).

#### 4.4 Typical wiring application

##### 4.4.1 Single -Pole

##### Connection way 1

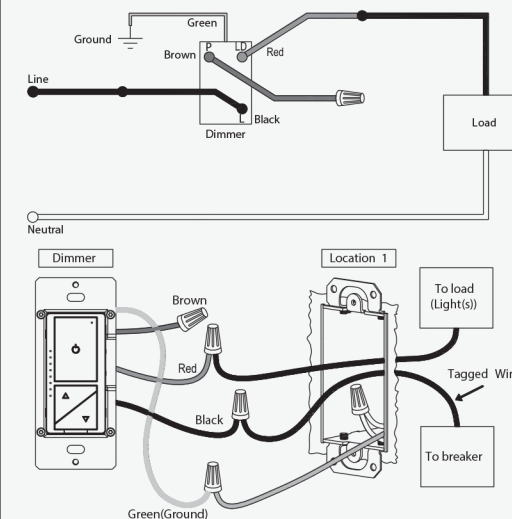

## 1. WARNINGS AND CAUTIONS

1.1 Risk of fire and electrical shock, the dimmer should be installed in accordance with appropriate electrical codes and regulations.

1.2 This product should be use with air switch.

1.3 Turn power off at circuit breaker or fuse and test that power is off before installing.

1.4 After install the dimmer, it is recommended to set the minimum brightness level to make bulbs turn on immediately.

1.5 If you are unsure about any part of these instructions, consult a licensed electrician.

1.6 To reduce the risk of overheating and possible damage to other equipment, do not install to control a receptacle, a motor-operated appliance or a transformer-supplied appliance.

1.7 Use with compatible dimmable LED, CFL bulbs, Incandescent or halogen bulbs only.

1.8 When multiple bulbs are used with one dimmer DO NOT mix bulb types. All bulbs shall be either LED, CFL or incandescent. Using the same model of each bulb will enhance dimmer performance.

#### Location 1 Connection:

- Connect the green wire on the dimmer with the green or bare copper ground wire on the wall box, and tighten it with the P3 wiring nut.
- Connect the black wire on the dimmer to the live wire of circuit breaker, and tighten it with the P3 wiring nut.
- Connect the red wire on the dimmer with the load wire, and tighten it with P3 wiring nut.
- Screw on the remaining brown wire on the dimmer with the p3 wiring nut to protect it.

#### 4.4.2 3-Way

##### 3-Way (3 -Way Switch)

Note: When in 3-Way connection, marking the two ends of Traveler 1 and Traveler 2 cables clearly at Location 1 and Location 2 to prevent connection errors.

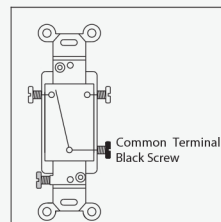

Note: The screws in the Common Terminal of 3 -Way Switch are of a different color (ex: black) and may be marked with an "H".

#### Dimmer Line Side

##### Connection way 2

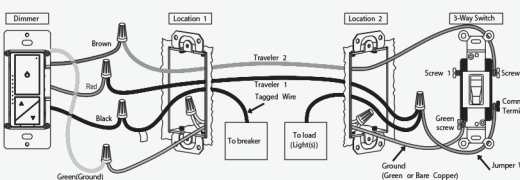
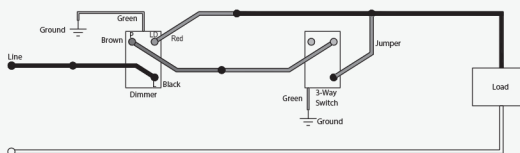

#### Location 1 Connection:

- Connect the green wire on the dimmer with the green or bare copper ground wire on the wall box, and tighten it with the P3 wiring nut.
- Connect the black wire on the dimmer to the labeled wire (the live wire of circuit breaker), and tighten it with the P3 wiring nut.
- Connect the brown wire on the dimmer to Traveler 2 and tighten it with P3 wiring nut.
- Connect the red wire on the dimmer to Traveler 1 and tighten it with P3 wiring nut.

#### Location 2 Connection:

- Connect the Traveler 2 to Screw 1 or Screw 2 on the 3-way Switch.
- Connect the 3-way Switch's Common Terminal to a Jumper wire. Traveler 1 is connected to the Jumper wire and load wire and secured with P3 wiring nut.

#### Dimmer Load Side

##### Connection way 3

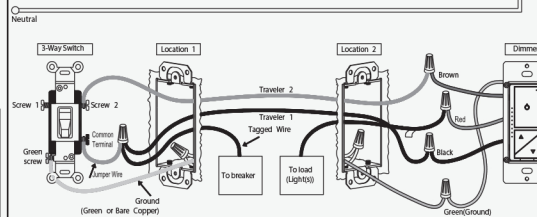
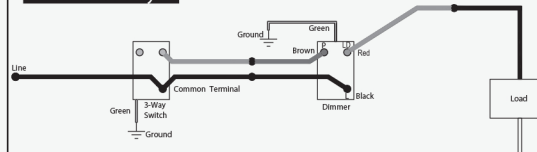

#### Location 1 Connection:

- Connect the Traveler 2 to Screw 1 or Screw 2 on the 3-way Switch.
- Connect the 3-way Switch's Common Terminal to a Jumper wire. Traveler 1 is connected to the Jumper wire and the live wire of circuit breaker, and tighten it with the P3 wiring nut.

#### Location 2 Connection:

- Connect the green wire on the dimmer to the green or bare copper ground wire on the wall box tighten with P3 wiring nut.
- Connect the black wire on the dimmer to Traveler 1 and tighten with P3 wiring nut.
- Connect the brown wire on the dimmer to Traveler 2 and tighten with P3 wiring nut.
- Connect the red wire on the dimmer with the labeled wire (Load Wire) and tighten with P3 wiring nut.

#### 3-Way (Toggle Switch)

Note: When in 3-Way connection, marking the two ends of Traveler 1 and Traveler 2 cables clearly at Location 1 and Location 2 to prevent connection errors.

#### Dimmer Line Side

##### Connection way 4

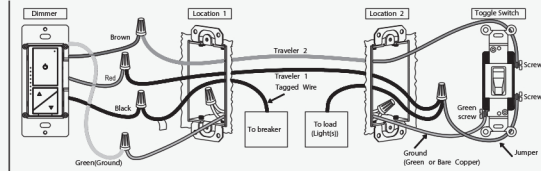
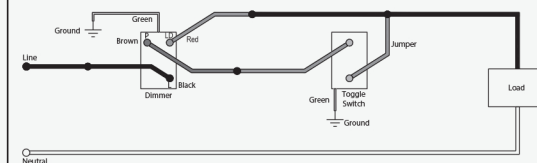

#### Location 1 Connection:

- Connect the green wire on the dimmer to the green or bare copper ground wire on the wall box, tighten with P3 wiring nut.
- Connect the black wire on the dimmer to the labeled wire (the live wire of circuit breaker), and tighten it with the P3 wiring nut.
- Connect the brown wire on the dimmer to Traveler 2 and tighten with P3 wiring nut.
- Connect the red wire on the dimmer to Traveler 1 and tighten with P3 wiring nut.

#### Location 2 Connection:

- Connect the Traveler 2 to Screw 1 on the Toggle Switch.
- Connect the Toggle Switch's Screw 2 to a Jumper wire. Traveler 1 is connected to the Jumper wire and the Load Wire, tighten with P3 wiring nut.

#### Dimmer Load Side

##### Connection way 5

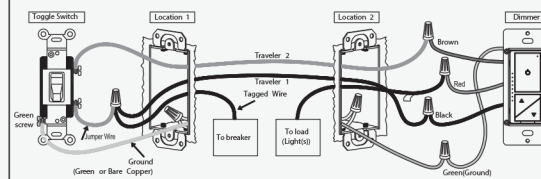
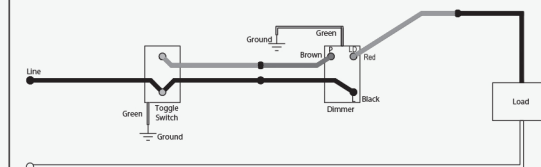

#### Location 1 Connection:

- Connect the Traveler 2 to Screw 1 on the Toggle Switch.
- Connect the Toggle Switch's Screw 2 to a Jumper wire. Traveler 1 is connected to the Jumper wire and the live wire of circuit breaker, and tighten it with the P3 wiring nut.

#### Location 2 Connection:

- Connect the green wire on the dimmer to the green or bare copper ground wire on the wall box, tighten with P3 wiring nut.
- Connect the black wire on the dimmer to Traveler 1 and tighten with P3 wiring nut.

- Connect the brown wire on the dimmer to Traveler 2 and tighten with P3 wiring nut.
- Connect the red wire on the dimmer to the labeled wire (Load Wire), and tighten with P3 wiring nut.

#### 4.5.1 Installing dimmer

- Carefully position all wires inside the wall box, leaving enough space to insert the dimmer. Secure the dimmer with the provided mounting screws.

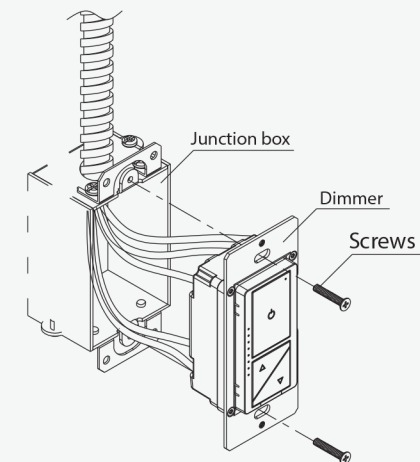

#### 4.5.2 Install panel

##### 4.5.2a split panel

- Installing the panel base on the dimmer and tighten with the screws.

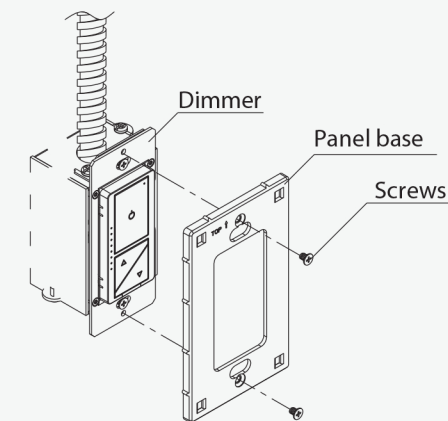

- Put the panel and panel base together, press gently to make sure it is installed firmly.

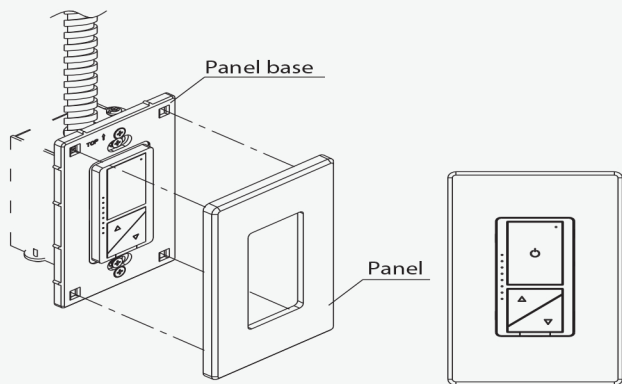

#### 4.5.2b Integrated panel

- Installing the panel on the dimmer and tighten with the screws.

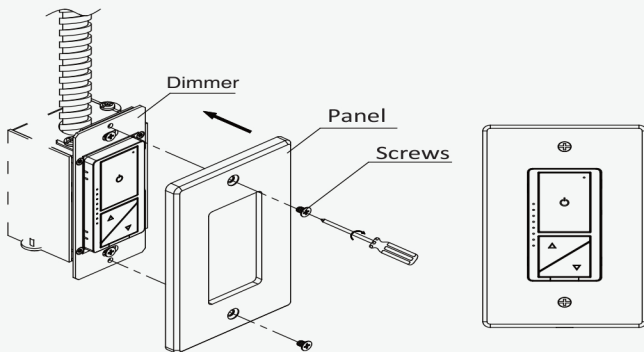

### 5. User Instructions

#### Function Declaration

Short press: Within 0.5s  
 Long press: Over 0.5s  
 Continuous short press: Each interval of short press should within 0.3s

**Table 1 Single-Pole**

Function	Dimmer Operation way	Dimmer Operation
ON/OFF	Short press the power button once	√
Dimming	Short or long press the dimming button (UP/Down)	√
Quickly turn to the Max.brightness	Continuous short press the dimming Button (UP) twice	√
Quickly turn to the Min.brightness	Continuous short press the dimming Button (Down) twice	√
Setting the Max.brightness	Short press the power button 8 times	√
	Short press the max.brightness button	
Setting the Min.brightness	Short press the power button 6 times	√
	Short press the min.brightness button	
Clear the Max. and Min.brightness	Short press the power button 9 times	√
Restore factory Settings	Short press the power button 10 times	√

**Table 2 3-Way**

Function	Dimmer Operation way	Dimmer Operation	3-way Switch or Toggle Switch operation
ON/OFF	Short press the power button once	√	√
Dimming	Short or long press the dimming button(Up or Down)	√	×
Quickly turn to the Max.brightest	Continuous short press the dimming Button (UP) twice	√	×
Quickly turn to the Min.brightest	Continuous short press the dimming Button (Down) twice	√	×
Setting the Max.brightness	Short press the power button 8 times	√	×
	Short press the max.brightness button	√	×
Setting the Min.brightness	Short press the power button 6 times	√	×
	Short press the min.brightness button	√	×
Clear the Max. and Min.brightness	Short press the power button 9 times	√	×
Restore factory Settings	Short press the power button 10 times	√	×

### 6.Troubleshooting

Problems	Possible Cause	Solution
Lights flickering	Bad connection.	Reconnect and fix the power cords .
	Multiple types bulbs, incur interference and cause flicker.	Change bulbs to same type.
	Abnormal	Put the power cut -off button out and cut off the power, then put the power cut -off button in and connect the power on again.
LED and CFL flickers at low end of dimming range	Load compatibility is not good.	Turn up lamp min . brightness properly.
Lamps can't be turn on	Circuit breaker has tripped.	Turn power on
	Fuse burn out	Change fuse
	Lamp burned out	Change lamp
Lights out of control	The wires are not connected properly	Reconnect the power cords.
	Abnormal	Put the power cut -off button out and cut off the power, then put the power cut -off button in and connect the power on again.
The dimmer cannot operate during 3-way connection	The line is incorrectly connected or disconnected	Check power cords.
	The 3 -way switch is abnormal	Replace the 3 -way switch